



SRE-2750

ELECTRA-RIDE™ LT
STAIRWAY ELEVATOR

Operator's Manual

**Technical Service email: service@bruno.com
www.bruno.com**

1780 EXECUTIVE DR., P.O. BOX 84, OCONOMOWOC, WI 53066 USA
TELEPHONE: (262) 567-4990
FAX: (262) 953-5501
1-800-882-8183
REV. 03-19-2007

PRODUCT REGISTRATION FORM



Product Registration Form
Please print in CAPITAL letters.

! Please be assured that Bruno **does not** share or sell the information you provide.

Last Name _____

First Name _____ M.I. _____

Street Address _____
include apartment no, suite no.

City _____ State _____

Zip/Postal Code/Country _____

Email Address _____

Telephone No. _____

Date of Purchase (mm/dd/yy) _____

Installer (if different than seller) _____

Where did you hear about Bruno? CHECK ALL THAT APPLY.

doctor/therapist _____

Bruno dealer radio _____

AARP publication other (please tell us): _____

Internet _____

local newspaper _____

Who was the primary decision maker for this purchase?

user of product care giver

family member doctor/health care provider

friend _____

Which of the following health issues are of concern to you? CHECK ALL THAT APPLY.

spinal injury post polio

arthritis muscular dystrophy

diabetes multiple sclerosis

stroke emphysema

other (please tell us): _____

Please rate your satisfaction with your Bruno dealer:

excellent good average poor

Please rate your satisfaction with your Bruno product:

excellent good average poor

Bruno reserves the right to use comments indicated on this form in its on-line, video, audio and printed materials. Names will be abbreviated to ensure the privacy and anonymity of the individual.

©2006,2005 Bruno Independent Living Aids, Inc.® Rev. 10/06

Bruno is pleased to provide you with this mobility-enhancing product.

The Product Registration Form is shipped in a plastic bag with this manual. It is very important that you fill out and return this form at your earliest convenience so that we may complete the warranty registration process for your unit.

The **serial number** is found on labels affixed to the manual, as well as on the unit itself.

Serial and model numbers must be provided when filing a warranty claim, requesting service or ordering parts. We encourage you to keep this information readily available at all times.

Please Note: The warranty for the SRE-2750 Stairway Elevator is *rendered null and void* if the unit is installed by anyone other than an authorized Bruno dealer.

Best wishes from the Bruno Team.

SRE-2750 Operator 03-19-2007

Table of Contents

Regulatory Information and Specifications	4
Safety	5-6
Parts of the SRE-2750	7
Circuit Breaker	8
Seating	9
Operation	10-11
Charging	12
Battery Charger.	13-14
Maintenance/Transmitter Battery Replacement	15
Troubleshooting.	16-17
Vacation and Long-Term Storage	18
Warranty	19-20

CSA CERTIFICATION

The "C" and "US" indicators adjacent to the CSA Mark signify that the product has been evaluated to the applicable CSA and ANSI/UL Standards, for use in Canada and the U.S., respectively. This "US" indicator includes products eligible to bear the "NRTL" indicator. NRTL, i.e. National Recognized Testing Laboratory, is a designation granted by the U.S. Occupational Safety and Health Administration (OSHA) to laboratories which have been recognized to perform certification to U.S. Standards.



SPECIFICATIONS

- Weight Capacity:* 275 lbs. (125 kg)
Control: constant pressure (armrest and two remotes)
Maximum Incline: 45 degrees
Seat Swivel: 0, 67 and (optional) 90 degrees, (or combination) both directions, at top and bottom
Power Supply: 100-240 VAC, 50/60 Hz, 0.85 amp power supply input, 33 VDC 1-amp transformer output, 29.6 to 27.6 VDC charging at 850 mA max., continuous monitoring.

FOR YOUR SAFETY

- Read and understand the operating instructions, and all safety precautions prior to using the SRE-2750.
- Be sure stairs are clear of objects before operating the stairway elevator.
- Always be aware of the surface onto which you are stepping as you get on and off the stairway elevator.
- Avoid carrying items with you on the stairway elevator which could hinder movement of the elevator up and down the stairs.
- Do not wear LOOSE clothing that could interfere with elevator movement.
- Fasten your positioning belt before operating the stairway elevator.
- Make sure the seat is locked in the correct riding position.
- Be certain the seat swivel is locked in place before attempting to get on or off the stairway elevator.

FOR YOUR SAFETY

Each stairway elevator is designed to descend the stairway at a slightly slower speed than is the case when travelling UP.

The footrest is equipped with *obstruction sensors* which stop the carriage if an obstacle is encountered on the stairs.

If this should occur, press the opposite side of the UP/DOWN rocker control switch (on the armrest) to run the carriage in the opposite direction. Clear the obstacle from the stairway or rail then resume travel in the desired direction.

Your SRE-2750 is battery powered and will continue to operate for some time during a power outage. The length of operation will depend on the battery condition, the length of the stairs and the weight of the rider.

Only in the event of a prolonged power outage (more than one hour) will it be necessary to turn the power off (circuit breaker switch on the carriage) and unplug the power supply from the wall outlet to conserve battery charge.

SRE-2750 ELECTRA-RIDE™ ELITE

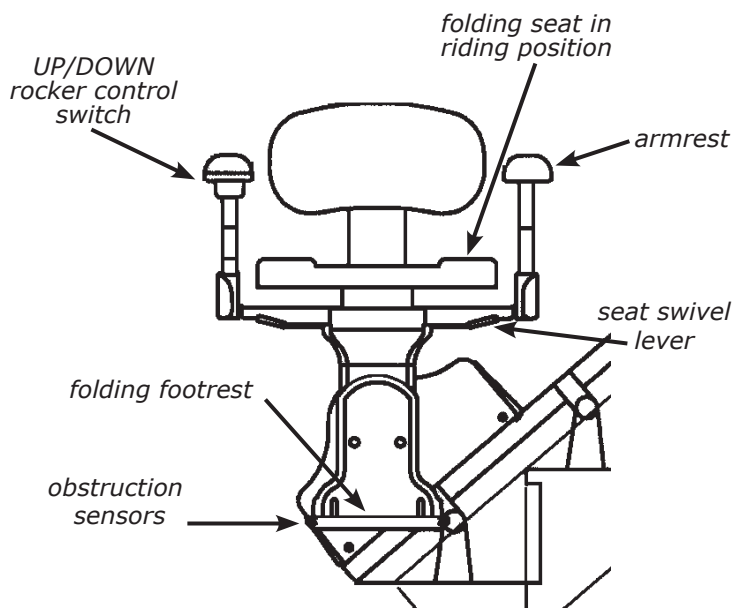

CIRCUIT BREAKER

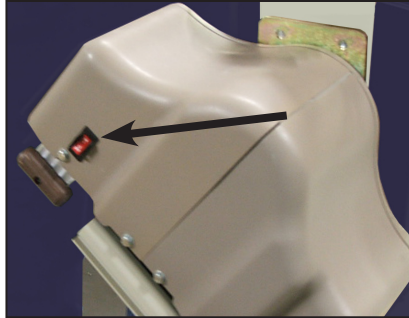

The SRE-2750 includes an ON/OFF switch with a built-in circuit breaker located on the carriage.

The circuit breaker protects the battery, controller and motor circuits in the stairway elevator carriage.

It is unlikely that this circuit breaker will trip during normal use. However, if the elevator becomes inoperative, check the circuit breaker as a first troubleshooting step. Reset it, if necessary.

Possible causes of circuit breaker tripping:

- foreign object jamming the rail or gear rack;
- exceeding the rated weight capacity of the stairway elevator.

SEATING

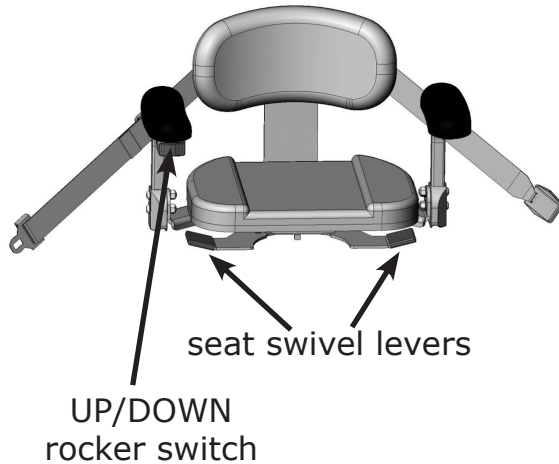

The seat assembly on the SRE-2750 is designed to swivel (with standard armrests) and to lock at 0, and 67 degrees.

Bruno offers, ***as an option***, the capability of setting a lock position at 90 degrees.

Lifting up on the swivel lever on either side of the seat allows you to swivel the seat to a convenient position for transferring into or out of the seat.

Once you release the swivel lever, the seat will lock.

To lower the seat assembly from a folded, up position, simply lower the seat to the riding position.

OPERATION

The SRE-2750 includes a "**soft-start**" feature which prevents the unit from moving abruptly the instant the UP/DOWN switch is pressed.

Press and hold the switch for a moment to begin the gentle acceleration of the stairway elevator to operating speed.

Depressing and holding the rocker switch will cause the carriage to move until the carriage stops automatically at the upper or lower end of the stair rail, or until the switch is released.

1. Position yourself in the seat.
2. Fasten the positioning belt.
3. Raise and hold the seat swivel lever.
4. Rotate the seat so that you are at right angles to the rail (with your back to the stairway wall).
5. Release the seat swivel lever to secure the seat in that position.
A safety switch prevents operation of the SRE-2750 unless the seat is locked in position at right angles to the rail (the "riding" position).
6. Position both feet securely on the footrest and place your arms on the armrest cushions.
7. Press and hold the rocker switch (located on the front edge of one of the armrests) to travel UP / DOWN the rail.

OPERATION

Two (2) remote call / send transmitters enable you to move the carriage to or from either end of the stair rail.

8. Once you have reached the top or bottom landing, release the rocker switch.
9. Raise and hold the seat swivel lever as you rotate to the position for transferring from the seat.
10. Release the seat swivel lever and allow the seat to lock in this position.
11. Unbuckle the positioning belt and carefully exit the seat.

CHARGING

Keep the batteries charged to ensure optimal operation of your SRE-2750.

The batteries are charging whenever the carriage is parked tightly against the brackets at either end of the rail. Whenever the carriage does not contact the upper or lower charge bracket, the batteries will slowly discharge.

Failure to keep the batteries charged, or allowing them to fully discharge, will significantly shorten the life of the batteries.

Therefore, when the stairway elevator is not in use, park the carriage at either end of the rail, making sure it touches the charge bracket contacts.

If your application prevents parking the carriage at one or the other end of the stairs (for example, a door at the top of the stairs), ***ALWAYS*** use the call/send transmitter to move the carriage to the end of the rail where the carriage *can* contact the charge bracket. Using the transmitter, call it back to the other end of the stairs when needed.

BATTERY CHARGER LED'S

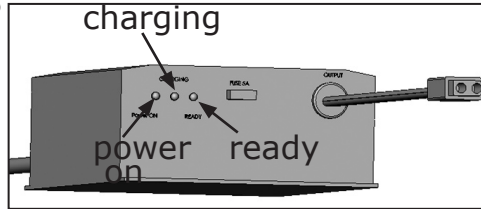

RED	YELLOW	GREEN	STATUS
ON	OFF	OFF	charger not connected to battery (AC power ON, no battery connected)
ON (5 sec.)	ON (5 sec.)	ON (5 sec.)	battery disconnect situation detected (AC power ON, battery disconnect); 10-second delay until yellow and green LED's completely off
ON	ON	OFF	charger at maximum voltage/ delivering maximum current
ON	SLOW BLINK	SLOW BLINK	batteries close to being fully charged
ON	ON	ON	batteries fully charged
ON	BLINK	OFF	low voltage indication
ON	OFF	FAST BLINK	battery defective or heavily sulfated

BATTERY CHARGER FUSE REPLACEMENT

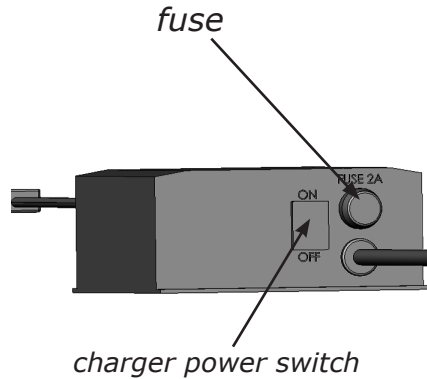

If the charger is subject to a power line surge, the AC input fuse may blow. Refer to the illustration to the left for fuse location.

To replace fuse:

1. Turn OFF the battery charger power switch.
2. Remove power cord from wall outlet.
3. Twist the fuseholder cap and pull out to remove the fuse.
4. Replace with the same size and type fuse: (BUSS # GSL 2) 5 x 20mm.

MAINTENANCE

Your SRE-2750 is designed to provide many years of reliable service with minimal maintenance.

For best service life:

- Keep the rail channel clean and free of debris.
- Always park the carriage at one end of the rail so that the batteries charge when the elevator is not in use.
- Keep the power supply plugged into a live outlet at all times.
- ***At least once a year***, have the elevator examined, cleaned and lubricated by a qualified, authorized Bruno service technician.



9V battery

(access panel
removed)

Transmitter Battery Replacement

To replace the battery in the call/send transmitters, remove the access panel on the back of the transmitter. One 9V battery required.

TROUBLESHOOTING

Your SRE-2750 is not operating correctly. What should you do?

Before calling your Bruno dealer, refer to the solutions listed below. This could save you an unnecessary service call!

- **Seat swivel.** Is the seat locked in the riding position?
- **Footrest.** Is there an obstruction on the stairway that the footrest is contacting?
- **Carriage safety panels.** Is there an obstruction on the stairway that the carriage safety panels are contacting?
- **Main circuit breaker (or fuse) panel of residence.** Has a breaker tripped or a fuse blown?
- **Power supply.** A discharged battery will cause the carriage to move more slowly until the voltage drops to the point where the controller will shut off.

If this should occur, pause for a moment, then run the carriage down until the unit contacts the upper or lower charge bracket.

Partially charged batteries will run the carriage down, but not up.

Continued on next page.

TROUBLESHOOTING (CONTINUED)

- **Power supply (continued).** Confirm that the power supply is plugged into a live outlet and wait for the batteries to charge.
Is the power supply plugged into a functional outlet? *Do not use outlets which are controlled by a wall switch.*
Is the power light on?
- **Visual check.** Do you notice anything about your elevator that is different or out of place?

If your SRE-2750 continues to function improperly or not at all after completing the preceding checklist, contact an authorized Bruno dealer to perform all required service, repair and maintenance operations.

VACATION AND LONG-TERM STORAGE

If the SRE-2750 will remain unused for an extended period of time, turn off the circuit breaker and unplug the power supply from the wall outlet.

NOTE: *The batteries may require recharging before normal use if the stairway elevator remained unused for an extended period of time.*

To recharge, simply turn on the circuit breaker, reconnect the power supply to the wall outlet and wait until the power supply LED's indicate that the batteries are fully recharged.

**FIVE YEAR MAJOR COMPONENTS WARRANTY
TWO YEAR LIMITED WARRANTY
for
Bruno Stairlifts**

Bruno Independent Living Aids, Inc. ("Bruno"), warrants to the original purchaser of a Bruno Stairlift that the Bruno Stairlift is free from defects in material and workmanship for a period of two years from date of purchase. In addition, Bruno warrants that the motor, gear box and rail (the "Major Components") will be free from defects in materials and workmanship for a period of five years from the date of purchase.

The exclusive remedy for a defect in a Bruno Stairlift shall be the repair or replacement, at the option of Bruno, of the defective part or component. After the first 30 days of this warranty, only parts and components are covered. This warranty does not cover labor and other services after the initial 30 days. If repair or replacement of a Bruno Stairlift is not commercially practical or cannot be timely made, Bruno may elect to refund the purchase price of the Bruno Stairlift instead of repairing or replacing the Bruno Stairlift.

IN NO EVENT SHALL BRUNO BE RESPONSIBLE FOR INDIRECT, INCIDENTAL OR CONSEQUENTIAL DAMAGES, WHETHER SUCH DAMAGES ARISE FROM CLAIMS BASED ON CONTRACT, WARRANTY, TORT (INCLUDING NEGLIGENCE), STRICT LIABILITY OR PRODUCT LIABILITY. Some states do not allow the exclusion or limitation of incidental or consequential damages, so the above limitation or exclusion may not apply to you.

ALL IMPLIED WARRANTIES, INCLUDING ANY WARRANTY OF MERCHANTABILITY OR FITNESS FOR A PARTICULAR PURPOSE, ARE LIMITED IN THEIR DURATION TO THE LENGTH OF THE WARRANTY STATED ABOVE FOR THE AFFECTED COMPONENT. Some states do not allow limitations on how long an implied warranty lasts so the above limitation may not apply to you.

To obtain warranty service, you must follow these procedures:

1. Obtain return authorization by calling your local Bruno dealer;
2. Return the Bruno Stairlift, freight prepaid, to the address provided by your Bruno dealer or Bruno with proof of purchase indicating the date purchased.

Bruno will pay for shipping back to the purchaser within the continental United States and Canada if a defect in material or workmanship is discovered. Return freight and repair charges will be the responsibility of the purchaser if the problem is not covered by warranty.

This warranty does not cover damage or failure caused by misuse, abuse, accidents, physical damage, modifications not made by Bruno, damage in shipment, or repairs undertaken by anyone other than Bruno factory employees or authorized distributors. The "original purchaser" of a Bruno Stairlift that is leased or rented shall be the person or entity acting as the lessee or rental provider.

This warranty gives you specific legal rights, and you may also have other rights which vary from state to state. Bruno specifically does not authorize any person to extend the time or scope of this warranty.

For further information regarding this limited warranty, please contact Bruno by calling 1-800-882-8183 or writing to Bruno at the following address:

Bruno Independent Living Aids, Inc.®
Attention: Service Department
1780 Executive Drive, Post Office Box 84
Oconomowoc, WI 53066 USA

First in Performance. Built to Last!



**Straight & Custom
Curved-Rail Stairlifts**



Vertical Platform Lift



**Over 25 Different
Vehicle Lift Solutions**



Turning Automotive Seating

Bruno Independent Living Aids, Inc.[®]

1780 Executive Drive, P.O. Box 84, Oconomowoc, WI 53066

262-567-4990 • FAX: 262-953-5501 • www.bruno.com

 **BRUNO[™]**
for your independence

©2006 Bruno Independent Living Aids, Inc.[®] All illustrations and specifications in this brochure are based on the latest product information available at the time of publication. Bruno Independent Living Aids, Inc.[®] reserves the right to make changes at any time without notice. Manual Back Cover 8/06-2.

P/N 2750-O